

**RECORD POWER**  
ESTABLISHED 1909®

## Original Instruction Manual

# DML305-VS Cast Iron Electronic Variable Speed Midi Lathe

Version 3.0  
November 2012



To register this product please visit  
**[www.recordpower.info](http://www.recordpower.info)**

It is important to register your product as soon as possible in order to receive efficient after sales support and be entitled to the full **5 year guarantee**. Your statutory rights are not affected. Please see back cover for contact details.



Always wear safety glasses when using woodworking equipment.



Always read the instructions provided before using woodworking equipment.

### Important

For your safety read instructions carefully before assembling or using this product.

Save this manual for future reference.



# Contents

- 1** Explanation of Symbols
  - 2** General Health & Safety Guidance
  - 3** Additional Health & Safety Guidance for Woodturning Lathes
  - 4** Record Power Guarantee
  - 5** Machine Description & Technical Specifications
  - 6** Assembly
  - 7** Adjustment
  - 8** Operation
  - 9** Intended Use of the Lathe & Basic Woodturning Instructions
  - 10** Dust Extraction
  - 11** Electrical Connection & Wiring Diagram
  - 12** Parts List & Diagram
- EU Declaration of Conformity

# 1. Explanation of Symbols

The symbols and their meanings shown below may be used throughout this manual. Please ensure that you take the appropriate action wherever the warnings are used.

## Mandatory Instructions



Read and fully understand the instruction manual before attempting to use the machine.



Indicates an instruction that requires particular attention



Wear protective eyewear



Use respiratory protective equipment



Use hearing protection



Use suitable protective footwear



Use protective work gloves

## Warnings



Indicates a risk of severe personal injury or damage to the machine



Indicates a risk of severe personal injury from electrical shock



Risk of personal injury from lifting of heavy items



Indicates a risk of severe personal injury from airborne objects



Risk of fire

## 2. General Health & Safety Guidance

**Ensure that you carefully read and fully understand the instructions in this manual before assembly, installation and use of this product. Keep these instructions in a safe place for future reference.**

**WARNING:** for your own safety, do not attempt to operate this machine until it is completely assembled and installed according to these instructions.

**WARNING:** When using any machine, basic safety precautions should always be followed to reduce the risk of fire, electric shock and personal injury.

### Safe Operation

#### 1. Use Personal Protective Equipment (PPE)

- The operation of any machine can result in foreign objects being thrown into your eyes, which can result in severe eye damage. Protective eyewear or other suitable eye protection or face shield should be used at all times. Everyday spectacles only have impact resistant lenses. They are not protective eyewear and do not give additional lateral protection.
- Use respiratory protective equipment (dust mask etc.) if the machining operation creates dust. Exposure to high levels of dust created by machining hardwoods, softwoods and man made composite boards can result in serious health problems. Some imported hardwoods give off highly irritating dust, which can cause a burning sensation. The use of respiratory protective equipment should not be seen as an alternative to controlling the risk of exposure at source by using adequate dust extraction equipment.
- The use of ear plugs or ear defenders is recommended when the machine is in use, particularly if the noise level exceeds 85 dB.
- Wear suitable protective gloves when handling cutting tools or blades. Gloves should NOT be worn when using the machine as they can be caught in moving parts of the machine.
- Non-slip safety footwear is recommended when using the machine and handling large work pieces.

#### 2. Dress appropriately

- Do not wear loose clothing, neckties or jewellery; they can be caught in moving parts of the machine.
- Roll up long sleeves above the elbow.
- Wear protective hair covering to contain long hair.

#### 3. Safety warnings

- Find and read any warning labels on the machine.
- It is important that any labels bearing health and safety warnings are not removed, defaced or covered. Replacement labels can be obtained by contacting our Customer Service Department.

#### 4. Familiarise yourself with the machine

- If you are not thoroughly familiar with the operation of this machine, obtain advice from your supervisor, instructor, or other qualified person or contact your retailer for information on training courses. Do not use this machine until adequate training has been undertaken.

#### 5. Take care when moving or positioning the machine

- Some machines can be very heavy. Ensure the floor of the area in which the machine is to be used is capable of supporting the machine.
- The machine and its various components can be heavy. Always adopt a safe lifting technique and seek assistance when lifting heavy components. In some cases it may be necessary to use mechanical handling equipment to position the machine within the work area.
- Some machines have optional wheel kits available to allow them to be manoeuvred around the workshop as required. Care should be taken to install these according to the instructions provided.
- Due to the nature of the design of some machines the centre of gravity will be high making them unstable when moved. Extreme care should be taken when moving any machine.

#### 6. The machine should be level and stable at all times

- When using a leg stand or cabinet base that is designed to be fitted to the machine, always ensure that it is securely fastened to the machine using the fixings provided.

- If the machine is suitable to be used on a workbench, ensure that the workbench is well constructed and capable of withstanding the weight of the machine. The machine should always be securely fastened to the workbench with appropriate fixings.
- Where possible, floor standing machines should always be secured to the floor with fixings appropriate to the structure of the floor.
- The floor surface should be sound and level. All of the feet of the machine should make contact with the floor surface. If they do not, either re-locate the machine to a more suitable position or use packing shims between the feet and the floor surface to ensure the machine is stable.

#### 7. Remove adjusting keys and wrenches

- Ensure that all adjusting wrenches and keys are removed before switching the machine 'ON'. There is a risk of severe personal injury or damage to the machine from airborne objects.

#### 8. Before switching the machine 'ON'

- Clear the machine table of all objects (tools, scrap pieces etc.)
- Make sure there is no debris between the work piece and the table / work support.
- Ensure that the work piece is not pressed against, or touching the saw blade or cutting tool.
- Check all clamps, work holding devices and fences to ensure that they are secure and cannot move during machining operations.
- Plan the way that you will hold and feed the work piece for the entire machining operation.

#### 9. Whilst machining

- Before starting work, watch the machine while it runs. If it makes an unfamiliar noise or vibrates excessively, switch the machine 'OFF' immediately and disconnect it from the power supply. Do not restart until finding and correcting the source of the problem.

#### 10. Keep the work area clear

- Working clearances can be thought of as the distances between machines and obstacles that allow safe operation of every machine without limitation. Consider existing and anticipated machine needs, size of material to be processed through each machine and space for auxiliary stands and/or work tables. Also consider the relative position of each machine to one another for efficient material handling. Be sure to allow yourself sufficient room to safely operate your machines in any foreseeable operation.
- Cluttered work areas and benches create the risk of accidents. Keep benches clear and tidy away tools that are not in use.
- Ensure that the floor area is kept clean and clear of any dust and debris that may create trip or slip hazards.

#### 11. Consider the work area environment

- Do not expose the machine to rain or damp conditions.
- Keep the work area well lit and ensure that there is artificial lighting available when there is insufficient natural light to effectively light the work area. Lighting should be bright enough to eliminate shadow and prevent eye strain.
- Do not use the machine in explosive environments eg. in the presence of flammable liquids, gases or dust.
- The presence of high levels of dust created by machining wood can present a risk of fire or explosion. Always use dust extraction equipment to minimise the risk.

#### 12. Keep other persons away (and pets)

- The machine is designed to be used by one person only.
- Do not let persons, especially children, touch the machine or extension cable (if used) and keep visitors away from the work area.
- Never leave the machine running unattended. Turn the power supply off and do not leave the machine unattended until it comes to a complete stop.
- If the work area is to be left unattended, all machinery should be switched 'OFF' and isolated from the mains power supply.

#### 13. Store machines safely when not in use

- When not in use, machines should be stored in a dry place, out of reach

## 2. General Health & Safety Guidance

of children. Do not allow persons unfamiliar with these instructions or with the machine to operate it.

### 14. Do not overreach

- Choose a working position that allows your body to remain balanced and feed the work piece in to the machine without overreaching.
- Keep proper footing and balance at all times.

### 15. Electrical supply

- Electrical circuits should be dedicated to each machine or large enough to handle combined motor amp loads. Power outlets should be located near each machine so that power or extension cables are not obstructing high-traffic areas. Observe local electrical guidelines for proper installation of new lighting, power outlets, or circuits.
- The machine must be connected to an earthed power supply.
- The power supply must be equipped with a circuit breaker that provides short circuit, overload and earth leakage protection.
- The voltage of the machine must correspond to the voltage of the mains power supply.
- The mains plug fitted to the machine should always match the power outlet. Do not modify the plug in any way. If a replacement plug is required it should be fitted by a competent person and of the correct type and rating for the machine.
- If you are unsure about any electrical connections always consult a qualified electrician.

### 16. Avoid unintentional starting of the machine

- Most machines are fitted with a no-volt release (NVR) switch to prevent unintentional starting. If in doubt always ensure the machine switch is in the 'OFF' position before connecting it to the power supply. This means the machine will not automatically start up after a power cut or switching on of the power supply, unless you first reset the start switch.

### 17. Outdoor use

- Your machine should not be used outdoors.

### 18. Extension cables

- Whenever possible, the use of extension cables is not recommended. If the use of an extension cable is unavoidable, then it should have a minimum core cross section of 2.5mm<sup>2</sup> and limited to a maximum length of 3 metres.
- Extension cables should be routed away from the direct working area to prevent a trip hazard.

### 19. Guard against electric shock

- Avoid body contact with earthed or grounded surfaces such as pipes and radiators. There is an increased risk of electric shock if your body is earthed or grounded.

### 20. Always work within the machine's intended capacities

- Operator safety and machine performance are seriously adversely affected if attempts to make the machine perform beyond its limits are made.

### 21. Do not abuse the power cable

- Never pull the power cable to disconnect it from the power socket. Always use the plug.
- Keep the power cable away from heat, oil and sharp edges.
- Do not use the power cable for carrying or moving the machine.

### 22. Secure the work piece

- Ensure that the work piece is securely held before starting to machine it.
- When working within 300 mm of the machining area, always use a push stick to feed the work piece in to the blade or cutting tool. The push stick should have a minimum length of 400 mm. If the push stick becomes damaged, replace it immediately.
- Use extra supports (roller support stands etc.) for any work pieces large enough to tip when not held down to the table top.
- Do not use another person as a substitute for a table extension, or as additional support for a work piece that is longer or wider than the basic table, or to help feed, support, or pull the work piece.
- Do not attempt to machine more than one work piece at a time.

- When feeding the work piece towards the blade or cutting tool never position your hands in direct line of the cutting path. Avoid awkward operations and hand positions where a sudden slip could cause your hand or fingers to move into the machining area.

### 23. Stay alert

- Safety is a combination of operator common sense and alertness at all times when the machine is being used.
- Use all machines with extreme care and do not use the machine when you are tired or under the influence of drugs, alcohol or medication.

### 24. Use the correct tool for the job

- Do not use the machine for any purpose other than which it was designed.
- When selecting replacement cutting tools and blades, always ensure that they are designed to cut the material that you intend to use them for. If in any doubt seek further advice from the manufacturer.

### 25. Connect dust extraction equipment

- Always use dust extraction equipment. The dust extractor should be of suitable size and capacity for the machine that it is connected to and have a filtration level appropriate to the type of waste being collected. Refer to the relevant section of the manual for details of the specific dust extraction requirements for this machine.
- The dust extractor should be switched 'ON' before starting the machine that it is connected to. The dust extractor should be left running for 30 seconds after the last machining operation is complete in order to clear any residual waste from the machine.

### 26. Ensure that the machine is correctly guarded

- Never use the machine if any of the standard safety guards and equipment are removed or damaged.
- Some machines incorporate safety interlocks to prevent the machine from being used without the guards in place. Never attempt to bypass or modify the interlocks to allow the machine to be used without the guards in place.

### 27. Maintain your machine with care

- This manual gives clear instructions on installation, set up and operation of the machine and also details any routine and preventative maintenance that should be performed periodically by the user.
- Remember always to switch off and unplug the machine from the power supply before carrying out any setting up or maintenance operations.
- Follow any instructions for the maintenance of accessories and consumables.
- Do not use compressed air to clean the machine. Always use a brush to dislodge dust in places that are awkward to reach and a dust extractor to collect the waste.
- Inspect electric cables periodically and, if damaged, have them replaced by an authorised service facility or qualified electrician.
- Inspect extension cables (if used) periodically and replace if damaged.

### 28. Keep cutting tools sharp and clean

- Correctly maintained cutting tools are easier to control and less likely to bind.
- Cutting tools and blades can become hot during use. Take extreme care when handling them and always allow them to cool before changing, adjusting or sharpening them.

### 29. Disconnect the machine from the power supply

- When not in use, before servicing, changing blades etc. always disconnect the machine from the power supply.

### 30. Check for damaged parts

- Before each use of the machine, it should be carefully checked to determine that it will operate properly and perform its intended function.
- Check for alignment of moving parts, binding of moving parts, breakage of parts and any other conditions that may affect the operation of the machine.
- A guard or other part that is damaged should be properly repaired

## 2. General Health & Safety Guidance

or replaced by a qualified person unless otherwise indicated in this instruction manual.

- Do not use the machine if the switch does not turn the machine 'ON' and 'OFF'.
- Have defective switches replaced by a qualified person.

### 31. Warning!

- The use of any accessory or attachment, other than those recommended in this instruction manual, or recommended by our Company may present a risk of personal injury or damage to the machine and invalidation of the warranty.

### 32. Have your machine repaired by a qualified person

- This machine complies with the relevant safety rules and standards appropriate to its type when used in accordance with these instructions and with all of the standard safety guards and equipment in place. Only qualified persons using original spare parts should carry out repairs. Failure to do this may result in considerable danger to the user and invalidation of warranty.

### 33. Caution! Motor may become hot during use

- It is normal for motors on some machines to become hot to the touch during use. Avoid touching the motor directly when in use.

## 3. Additional Health & Safety for Woodturning Lathes

### Safe Operation

#### Familiarise yourself with the machine

- Machining operations using wood turning lathes have a history of serious accidents. Most serious accidents resulted from the work piece being thrown from the lathe whilst turning. Other accidents can be caused by loose clothing being drawn in to the rotating work piece or hands becoming trapped between the rotating work piece and fixed parts of the lathe.

#### 2. Before switching the machine 'ON'

- Before attaching a work piece to a faceplate, always prepare it to be as round as possible. This will minimise vibration whilst turning. For further instructions please see the section of this manual entitled **Intended Use of the Lathe & Basic Woodturning Instructions**.
- Adjust the tool rest to the correct height and distance from the work piece and check that all fixings are secure.
- Check that the size of the work piece is within the safe working capacities of the lathe as detailed in the manual.
- Select the correct speed according to the size and type of work piece. The slowest speed is the safest speed to start any new work piece.
- Always rotate the work piece by hand before starting the lathe to ensure it does not come into contact with the tool rest. If the work piece strikes the tool rest during operation, it could be split and thrown from the lathe.
- When using a faceplate always ensure the work piece is well secured with screws of a suitable diameter and length.
- Remove any loose knots and bark from the work piece before mounting it to the lathe.
- If mounting a work piece between centres, always ensure that the tailstock is correctly adjusted and fully secure. Check that the locking handle for the tailstock barrel is fully tightened.

#### 3. Whilst using the lathe

- Do not allow the turning tool to dig in to the work piece, which could result in the work piece splitting or being thrown from the lathe. Always position the tool rest at the correct height. For further instructions please see the section of this manual entitled **Intended Use of the Lathe & Basic Woodturning Instructions**.
- Before starting to machine a work piece that is off centre or not perfectly round, always set the machine to the slowest speed and gradually increase speed as the work piece becomes more balanced as material is removed. Running the lathe too fast could cause the work piece to be thrown from the lathe or the turning tool to be snatched from your hands.
- Always store turning tools in a safe place away from the work area of the lathe. Never reach over the rotating work piece to reach for turning tools or accessories.
- Never attempt to adjust the position of the tool rest whilst the machine is running. Always switch the machine 'OFF' and wait until the work piece has stopped rotating before attempting any adjustments.
- Do not mount a work piece that contains excessive splits or loose knots or bark.

- Keep firm hold and control of the turning tool at all times. Use extreme caution when knots and voids are exposed in the work piece.

- Finish all hand sanding before removing the work piece from the lathe. Do not exceed the speed used for the last cutting operation. For further instructions please see the section of this manual entitled **Intended Use of the Lathe & Basic Woodturning Instructions**.

- Do not attempt to remount a work piece that has been turned on a faceplate unless you are deliberately turning eccentric work. You cannot remount faceplate turned work and expect it to run true, as the timber will have expanded or contracted.
- Do not remount a work piece that has been turned between centres if the original centres have been altered or removed, unless you are deliberately turning eccentric work.
- If re-mounting any work piece, always set the machine to the slowest speed and gradually increase the speed as the work piece becomes more balanced as material is removed.
- Use extra caution when mounting a work piece that has been turned between centres to a faceplate, or when mounting a faceplate turning between centres, for subsequent machining operations. Always ensure that the lathe is set to the slowest speed before switching ON.
- Do not attempt to perform any machining operations when holding the work piece by hand.
- Do not mount a reamer, milling cutter, wire wheel, buffing wheel, drill bit or any other tool to the headstock spindle.
- Always ensure that the turning tool is in contact with the tool rest and fully supported before applying the tool to the work piece.
- When the tool rest base unit is not in use (e.g. when sanding), it should be moved away from the headstock, and the tool rest removed.

#### 4. Maintenance

- Before attempting any maintenance and particularly when cleaning the machine, always remove any accessories and tooling from the machine.
  - Always ensure that any accessories used on the lathe are kept clean and free from rust and deposits of resin.
  - Keep all turning tools sharp and in good condition. Check that the handles are secure and not split or damaged.
5. This machine falls under the scope of the 'Health & Safety at Work etc. Act 1974', and the 'Provision & Use of Work Equipment Regulations 1998'. In addition the elimination or control of risks from wood dust is included in the above regulations and the 'Control of Substances Hazardous to Health (COSHH) Regulations 2002'. We recommend that you study and follow these regulations.

Further guidance is available from The Health & Safety Executive and their website [www.hse.gov.uk](http://www.hse.gov.uk) and from the authorised distributor in your country (details on back cover of the manual).

# 4. Record Power Guarantee

“**Products**” means the Products sold by Record Power subject to these terms and conditions;

“**Record Power**” is Record Power Limited, whose company registration number is 4804158 and registered office address is Unit B, Ireland Industrial Estate, Adelphi Way, Staveley, Chesterfield, S43 3LS and sells through a network of Authorised Dealers;

“**Authorised Distributor**” is the nominated importer for your region who will generally sell through a network of Authorised Dealers. Details of Authorised Distributors for specific countries can be found in the Product manual or at [www.recordpower.info](http://www.recordpower.info);

“**Authorised Dealer**” is a retailer or business authorised to sell Record Power Products to end users.

## 1 Guarantee

- 1.1 Record Power guarantees that for a period of 5 years from the date of purchase the components of qualifying Products (see clauses 1.2.1 to 1.2.9) will be free from defects caused by faulty construction or manufacture.
- 1.2 During this period Record Power, its Authorised Distributor or Authorised Dealer will repair or replace free of charge any parts which are proved to be faulty in accordance with paragraphs 1.1 above provided that:
  - 1.2.1 you follow the claims procedure set out in clause 2 below;
  - 1.2.2 Record Power, our Authorised Distributor or Authorised Dealer are given a reasonable opportunity after receiving notice of the claim to examine the Product;
  - 1.2.3 if asked to do so by Record Power, its Authorised Distributor or Authorised Dealer, you return the Product, at your own cost, to Record Power’s premises or other approved premises such as those of the Authorised Distributor or supplying Authorised Dealer, for the examination to take place;
  - 1.2.4 the fault in question is not caused by industrial use, accidental damage, fair wear and tear, wilful damage, neglect, incorrect electrical connection, abnormal working conditions, failure to follow our instructions, misuse, or alteration or repair of the Product without our approval;
  - 1.2.5 the Product has been used in a domestic environment only;
  - 1.2.6 the fault does not relate to consumable Products such as blades, bearings, drive belts or other wearing parts which can reasonably be expected to wear at different rates depending on usage (for full details contact Record Power or your local Authorised Distributor);
  - 1.2.7 the Product has not been used for hire purposes, by you or by a previous owner;
  - 1.2.8 the Product has been purchased by you as the guarantee is not transferable from a private sale.
  - 1.2.9 where the Product has been purchased from a retailer, the 5 year guarantee is transferable and begins on the date of the first purchase of the Product and in the event of a claim under this guarantee proof of the original purchase date will be required to validate the warranty period.

## 2 Claims Procedure

- 2.1 In the first instance please contact the Authorised Dealer who supplied the Product to you. In our experience many initial problems with machines that are thought to be due to faulty parts are actually solved by correct setting up or adjustment of the machines. A good Authorised Dealer should be able to resolve the majority of these issues much more quickly than processing a claim under the guarantee.
- 2.2 Any damage to the Product resulting in a potential claim under the guarantee must be reported to the Authorised Dealer from which it was purchased within 48 hours of receipt.
- 2.3 If the Authorised Dealer who supplied the Product to you has been unable to satisfy your query, any claim made under this Guarantee should be made directly to Record Power or its Authorised Distributor (for details of the Authorised Distributor in your country please see your Product manual or check [www.recordpower.info](http://www.recordpower.info) for details). The claim itself should be made in a letter setting out the date and place of purchase, and giving a brief explanation of the problem which has led to the claim. This letter should then be sent with proof of the purchase date (preferably a receipt) to Record Power or its Authorised Distributor. If you include a phone number or email address this will help to speed up your claim.
- 2.4 Please note that it is essential that the letter of claim reaches Record Power or its Authorised Distributor on the last day of this Guarantee at the latest. Late claims will not be considered.

## 3 Limitation of Liability

- 3.1 We only supply Products for domestic and private use. You agree not to use the Product for any commercial, business or re-sale purposes and we have no liability to you for any loss of profit, loss of business, business interruption or loss of business opportunity.
- 3.2 This Guarantee does not confer any rights other than those expressly set out above and does not cover any claims for consequential loss or damage. This Guarantee is offered as an extra benefit and does not affect your statutory rights as a consumer.

## 4 Notice

This Guarantee applies to all Products purchased from an Authorised Dealer of Record Power within the United Kingdom of Great Britain and Northern Ireland. Terms of Guarantee may vary in other countries – please check with the Authorised Distributor in your country (details of the Authorised Distributor for your country can be found in the manual or at [www.recordpower.info](http://www.recordpower.info)).

# 5. Machine Description & Technical Specifications

## MACHINE IDENTIFICATION

There is a plastic identification plate fixed to the machine, containing the specifications and serial number.

## GETTING TO KNOW YOUR MACHINE

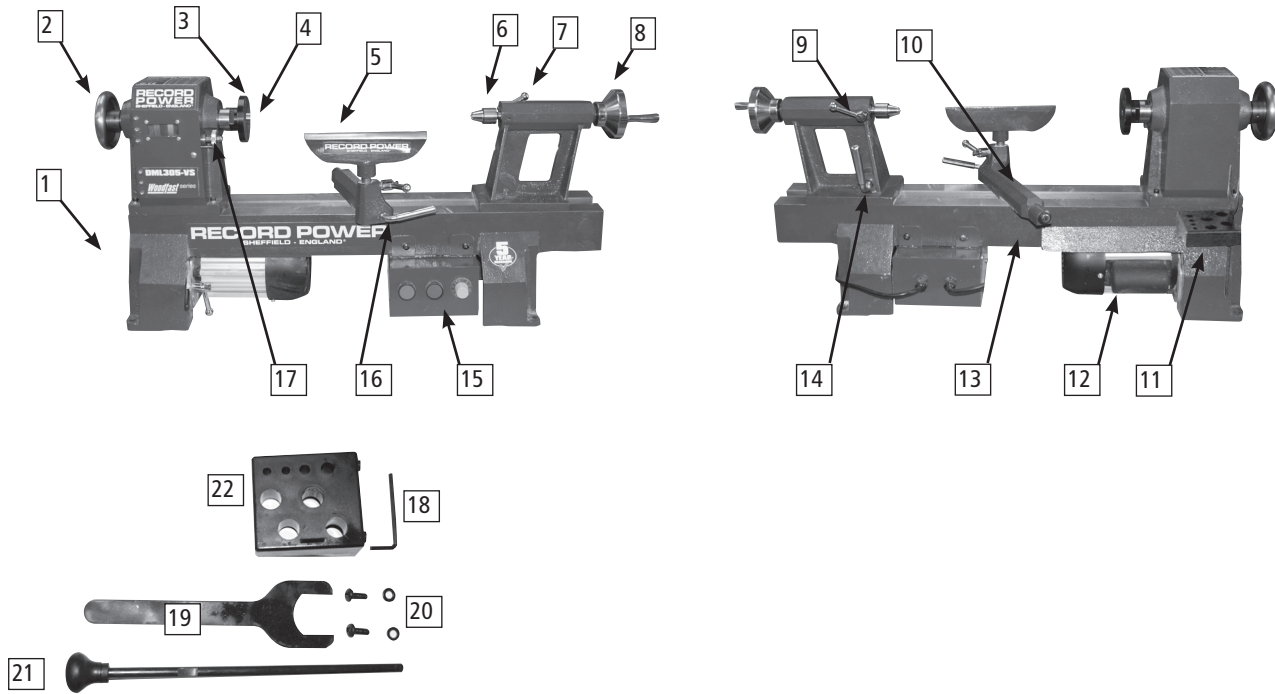

- |   |                      |    |                               |    |                                       |
|---|----------------------|----|-------------------------------|----|---------------------------------------|
| 1 | Lifting handle       | 9  | Tailstock spindle locking arm | 17 | Indexing lock                         |
| 2 | Handwheel            | 10 | Tool rest base                | 18 | 4 mm Allen key                        |
| 3 | Face plate           | 11 | Tool holder                   | 19 | Spanner                               |
| 4 | 4 prong drive centre | 12 | Motor                         | 20 | 2 x screw and washers for tool holder |
| 5 | Tool rest            | 13 | Lathe bed                     | 21 | Knock out bar                         |
| 6 | Revolving centre     | 14 | Tailstock locking lever       | 22 | Tool holder                           |
| 7 | Tailstock            | 15 | Switch and speed control unit |    |                                       |
| 8 | Tailstock handwheel  | 16 | Tool rest base locking lever  |    |                                       |

## SPECIFICATIONS

- |  |   |
|--|---|
| <b>Swing over bed:</b>                   | 305 mm  |
| <b>Swing over tool rest base:</b>        | 240 mm  |
| <b>Working distance between centres:</b> | 406 mm  |
| <b>Motor:</b>                            | 230V / 50 Hz, 1/2 hp / 375 W  |
| <b>Full load current:</b>                | 4.6 A   |
| <b>Speed ranges:</b>                     | 170-1170, 290-2040, 540-3840rpm   |
| <b>Thread:</b>                           | 3/4" x 16 TPI or M33 x 3.5 mm (please refer to machine specification label) |
| <b>Taper:</b>                            | 1 or 2 Morse Taper (please refer to machine specification label)            |
| <b>Hole through spindle:</b>             | 9.5 mm  |
| <b>Tailstock spindle travel:</b>         | 63.5 mm   |
| <b>Noise Emission:</b>                   | Sound power level < 83 dB (A)<br>Sound pressure level < 83 dB (A)           |

# 6. Assembly

## Installing Tool Rest on to the Lathe Bed

Loosen locking arm and insert tool rest into tool rest base, adjust height as required and tighten the locking arm. **Fig.6.1.**

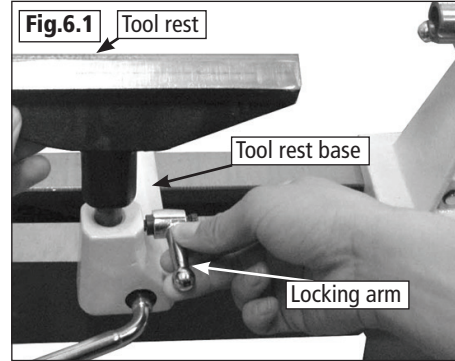

## Fitting the 4-Prong Drive to the Headstock

Insert the drive centre, with a No.1 Morse Taper shank, into the headstock spindle. **Fig.6.2.**

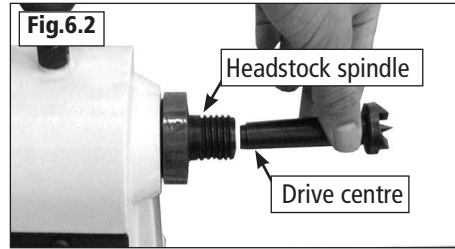

## Fitting the Revolving Centre to the Tailstock

Insert the live centre, with a No. 1 Morse Taper shank into the tailstock spindle. **Fig.6.3.**



**Please note: Before inserting tapered attachments into the headstock or tailstock spindle, always ensure that the taper is clean and free of any waste material that may cause misalignment or vibration. Always fully seat the taper by tapping it squarely into place with a wooden mallet.**

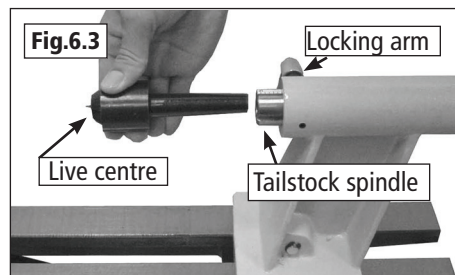

## Fitting Tool Holder to the Lathe Bed

Locate the tool holder from the carton and install it onto the lathe bed with two pan head screws. **Fig.6.4.**

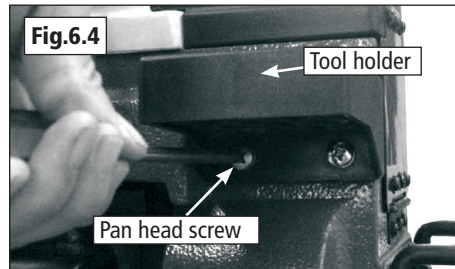

## Secure Lathe to a Solid Work Surface

The lathe must be attached to a solid work surface or stand, not less than 25mm thick. Four mounting holes are easily accessible at the base of the lathe. **Fig.6.5.** Drill holes in the work surface, using a 1/2" or 13mm drill bit, following the dimensions below.

**Note: Use of the DML305/A Adjustable Stand is recommended.**

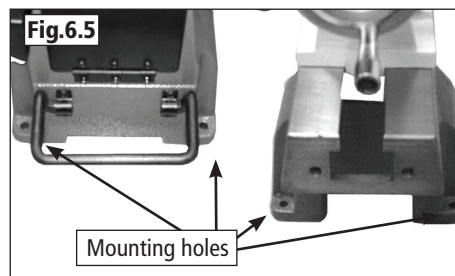
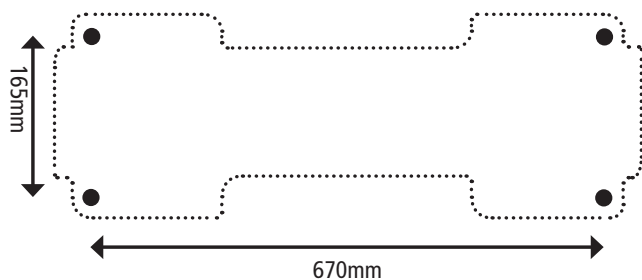

## 6. Assembly - Optional Leg Stand

### Assembling the Optional Leg Stand

- 1 Upright plinth x 2
- 2 Male cross brace
- 3 Female cross brace
- 4 M10 x 25mm set screw x 2
- 5 M8 x 35mm bolt x 2
- 6 M10 x 80mm bolt x 2
- 7 Upright column x 2
- 8 Base x 2



## 6. Assembly - Optional Leg Stand - cont.

1. Attach the upright column to the base using two M10 x 80mm bolts, ensuring that there is an M10 washer between the bolt and the upright column another M10 washer between the M10 nut and the base. **Fig.6.6.** Repeat this process to assemble the second base onto the second upright column.

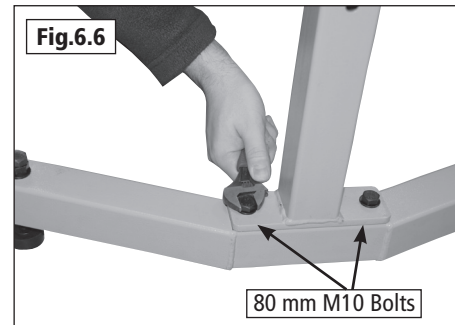

2. Attach the upright plinth to the upright column using two M10 x 80mm bolts to the desired height, making sure that the overhang of the plate on top of the plinth is facing towards the inside of the legstand. Also ensure that there is at least one hole space between the two bolts and that both bolts pass through the upright column. **Fig.6.7.** Repeat this process to complete the assembly of the second leg.

**Please note: The leg stand is adjustable in height to allow for comfortable use of the lathe. As a general rule, the centre height of the lathe should be at elbow height.**

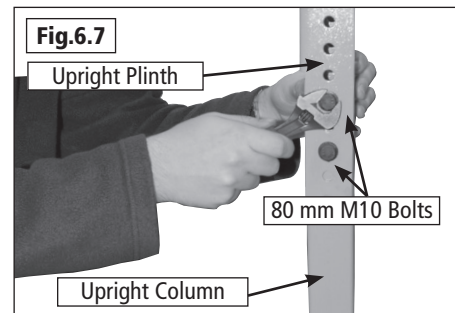

3. Attach the female cross brace to one of the upright columns using two M10 x 80mm bolts. Attach the male cross brace to the remaining upright column in the same manner. **Fig.6.8.**

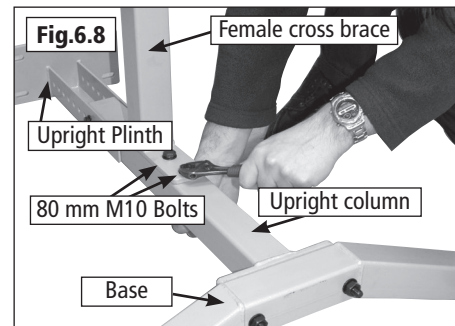

4. To complete assembly of the legstand, insert the male cross brace into the female cross brace, ensuring that the distance from the inside of one leg to the other is approximately 590mm. Hold in place using two M10 x 25mm set screws. **Fig.6.9.**

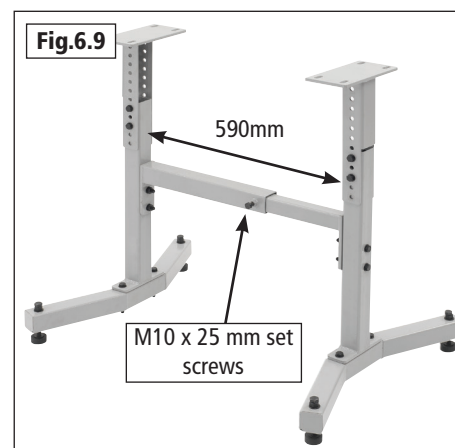



# 6. Assembly - Optional Leg and Bed Extension

## Assembling the Optional Bed & Leg Extension

Leg stand parts:

- 1 Upright Plinth
- 2 Male Cross brace
- 3 Female Cross brace
- 4 M10 x 25mm Set Screw x2
- 5 M8 x 35mm Bolt x2
- 6 M10 x 80mm Bolt x2
- 7 Upright Column
- 8 Base



Bed Extension Parts:

- 1 M10 x 50mm Bolt x2
- 2 M8 x 35mm Bolt x2
- 3 M10 Washer x2
- 4 M8 Washer x4
- 5 M10 Spring Washer x2
- 6 M8 Nut x2
- 7 Allen Key
- 8 Bed Extension

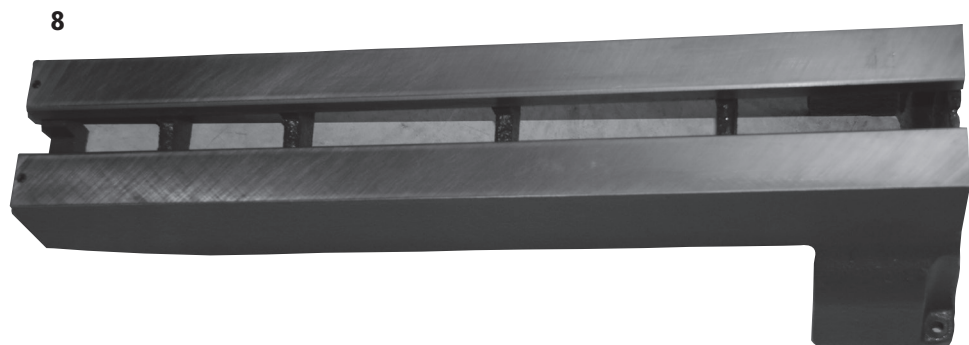
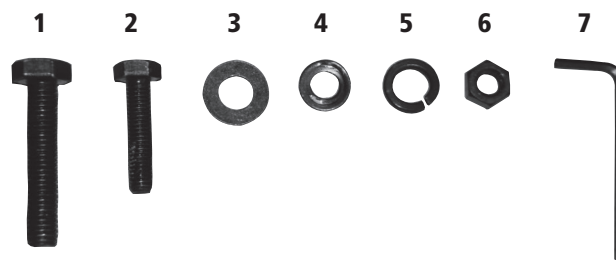

## 6. Assembly - Optional Leg and Bed Extension - cont.

1. Attach the upright column to the base using two M10 x 80 mm bolts, ensuring that there is an M10 washer between the bolt and the upright column another M10 washer between the M10 nut and the base, **Fig.6.10**.

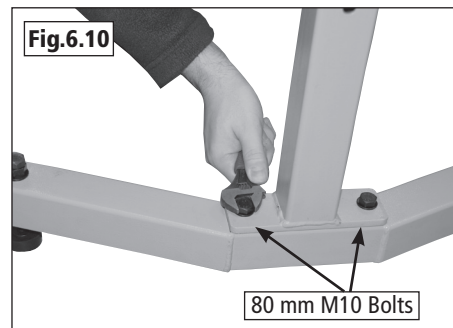

2. Attach the upright plinth to the upright column using two M10 x 80 mm bolts to the desired height, making sure that the overhang of the plate on top of the plinth is facing towards the inside of the legstand. Also ensure that there is at least one hole space between the two bolts and that both bolts pass through the upright column, **Fig.6.11**.

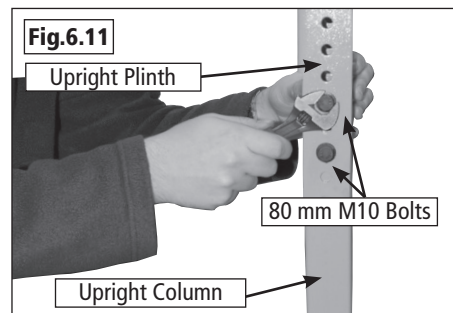

3. Attach the female cross brace to one of the upright columns using two M10 x 80 mm bolts, **Fig.6.12**.

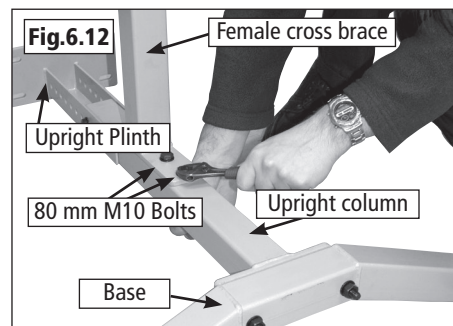

4. Attach the male cross brace to the main leg stand using the bolts from the main cross brace, **Fig 6.13**.

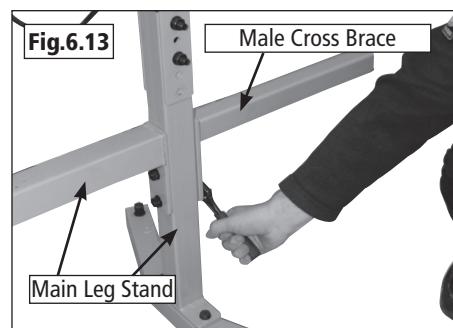

5. Set the distance between the main leg stand and the new leg extension to approximately 640mm (25") so that the bed extension can sit on the leg extension safely. Hold in place by attaching the two M10 x 25mm set screws in the female cross brace, **Fig 6.14**.

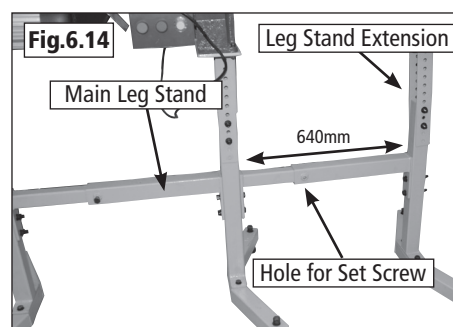

## 6. Assembly - Optional Leg and Bed Extension - cont.

1. Place an M10 spring washer then M10 washer onto a M10 x 50mm bolt and screw into the hole on the end of the original bed leaving approximately 20mm of the 50mm M10 bolt exposed, **Fig 6.15**.
2. Repeat this process for the adjacent hole.
3. Place the bed extension onto the exposed M10 x 50 mm bolts and tighten the bolts so that it holds the bed extension in place. Do not tighten the bolts fully as some fine tuning will still be required so that the tailstock runs smoothly between the original bed and the bed extension, **Fig 6.16**.
4. Using the Allen key (supplied) use the grub screws on top of the bed extension to raise (turn clockwise) or lower (turn anti-clockwise) the extension until it is flush with the main bed of the lathe, **Fig.6.17**.
5. Attach the foot of the bed extension to the top of the upright plinth using an M8 x 35 mm bolt with an M8 washer on either side of the bed extension and hold together with an M8 nut, **Fig 6.18**.
6. Finally begin to tighten up the M10 x 50mm bolts to hold the bed extension as securely as possible making sure that the tailstock runs smoothly between the original bed and the bed extension. Fine tuning may be required during this process, this can be done using a soft mallet (not supplied) without causing damage to the product, **Fig.6.19**.

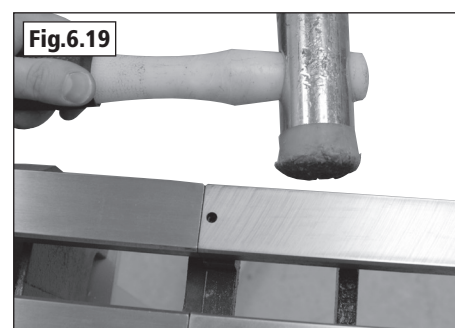
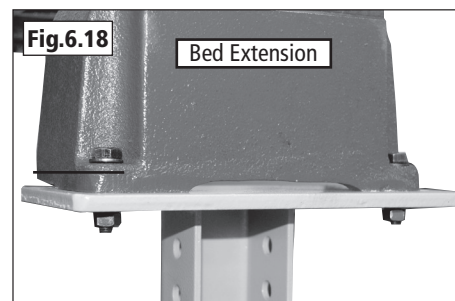
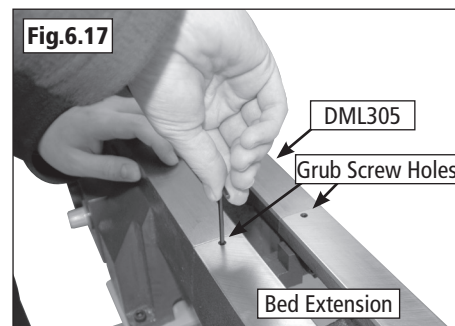
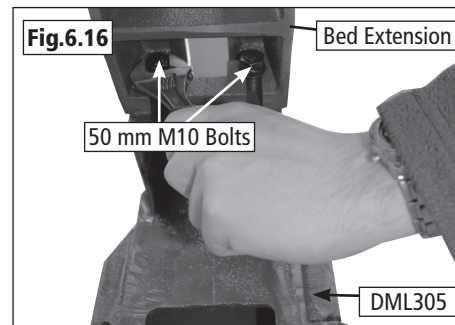
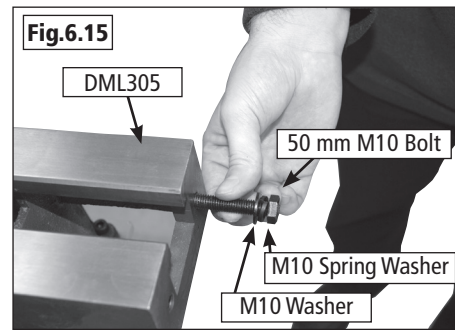

# 7. Adjustment

## 7.1 Knockout Bar

The knockout bar is used to remove the drive centre from the headstock spindle. Insert knockout bar into hole at opposite side from drive centre, see **Fig 7.1**.

To remove the revolving centre from the tailstock, loosen locking handle and rotate the hand wheel counter-clockwise to retract the spindle into the body of the tailstock. The revolving centre will be pushed out of the spindle, **Fig 7.2**.

## 7.2 Fitting the Faceplate to the Headstock

Thread the faceplate clockwise onto the headstock spindle and tighten faceplate with supplied spanner, **Fig 7.3**.

To remove the faceplate, hold the spindle with the supplied spanner to stop the spindle from turning and loosen the faceplate with supplied spanner. Unthread the faceplate anti-clockwise from the headstock spindle.

## 7.3 Adjusting the Tool Rest

The tool rest base can be easily moved along the lathe bed. Loosen locking lever counter clockwise, slide the tool rest base to its new position, and tighten locking lever clockwise.

To adjust the height of the tool rest, loosen the locking arm, raise or lower the tool rest then tighten locking arm, **Fig 7.4**.



**Please note: Position the tool rest as close to the work piece as possible. It should be 3.5mm above the centre line of the workpiece.**

To adjust clamping action of the tool rest base, remove base and adjust nut clockwise to tighten and counterclockwise to loosen, **Fig 7.5**. Tightening the nut will increase the sensitivity of the cam mechanism and increase the clamping force. Loosening the nut will reduce the clamping force of the cam.

## Indexing Lock

The indexing lock is positioned on the front of the headstock for ease of use. The headstock indexing feature has 12 equally spaced positions. The spring loaded locking pin assembly is engaged by turning the knob a half turn allowing it to drop into the desired position. To disengage, lift the lock knob up and turn a half turn either direction. **Fig 7.6**.

The 12 position indexing feature allows accurate pattern work on projects such as straight fluting, grooving, drilling, lay out and more.

To use the indexing feature, disengage the locking knob by lifting up and rotating a half turn. The pin hole will engage in the closest pin available.



**Please note: The indexing mechanism should not be used as a method of holding the spindle whilst removing accessories such as face plates, chucks etc. Always hold the spindle with a spanner on the spindle nose when removing accessories.**

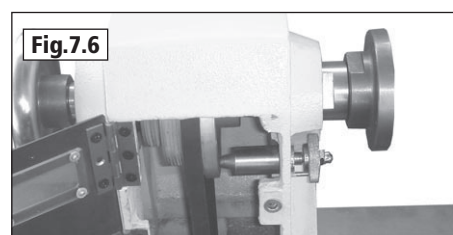
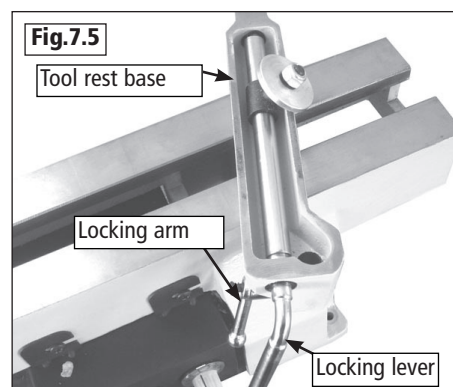
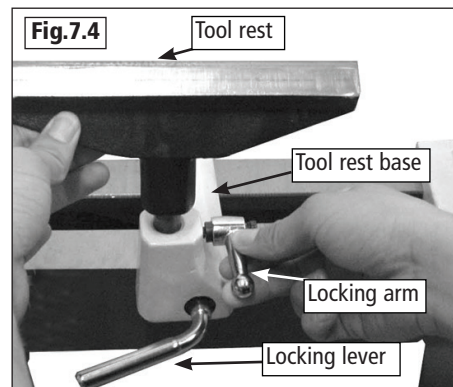
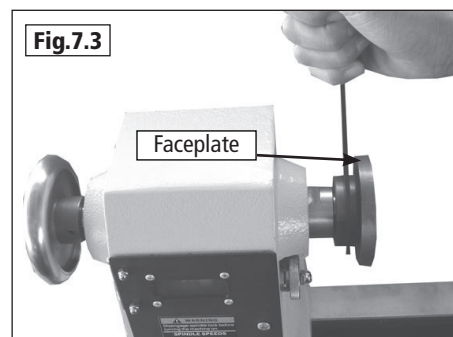
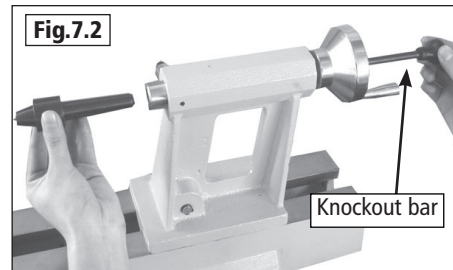
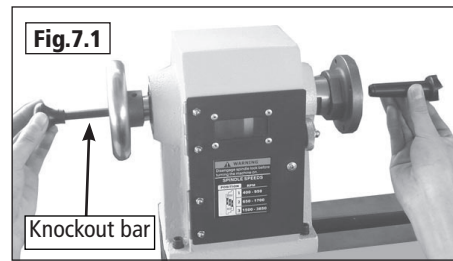

## 7.4 Adjusting the Tailstock

Loosen locking lever to move the tailstock along the lathe bed to desired position. Tighten lever.

To adjust clamping action of the tailstock, remove it from lathe bed and adjust nut clockwise to tighten and counterclockwise to loosen, **Fig 7.7**. Tightening the nut will increase the sensitivity of the cam mechanism and increase the clamping force. Loosening the nut will reduce the clamping force of the cam.

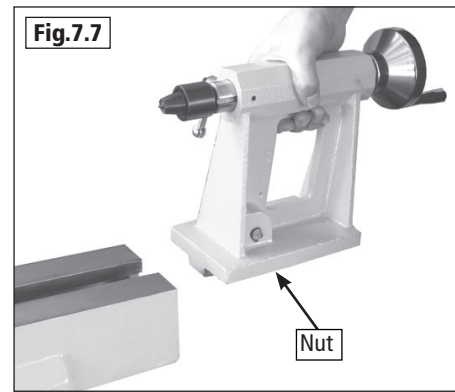

To adjust the position of the tailstock loosen locking arm and rotate the handwheel. When the tailstock arm is in the desired position, tighten locking arm, **Fig 7.8**.

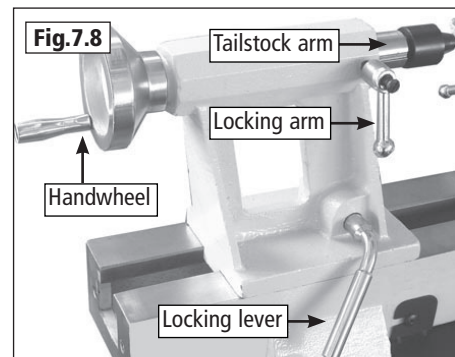

## 7.5 Changing Spindle Speeds

The lathe features a three step motor and spindle pulleys to provide different spindle speed ranges. Open the access cover to change spindle speeds, **Fig 7.9**.

With the access cover open loosen the locking arm. Raise the lever to release the tension on the motor pulley and tighten locking arm. Check the speed and belt position chart outside access cover to determine the spindle speed required.

Move the drive belt to the desired pulley combination. Loosen locking arm, lower lever and the weight of the motor will provide the correct tension on the drive belt. Tighten locking arm and close access cover, **Fig 7.9**.

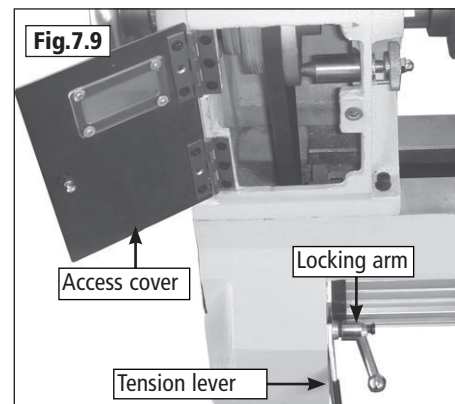

# 8. Operation

**Caution:**  
Disengage indexing lock before turning the machine on.

## 8.1. On/Off Switch

See Fig 8.1.

To switch ON press green switch button.

To switch OFF press red switch button.

To adjust the motor speed turn the speed control knob. To increase the speed, rotate clockwise and to reduce the speed rotate anti-clockwise.

Always start the machine with the control knob set to the lowest speed and gradually increase to the required speed as the workpiece becomes more concentric.

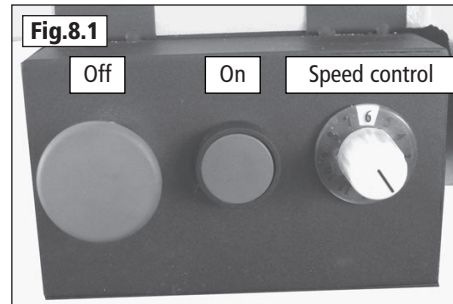

## 8.2. Typical Operations

The lathe is set up for a typical spindle turning operation. See Fig 8.2.

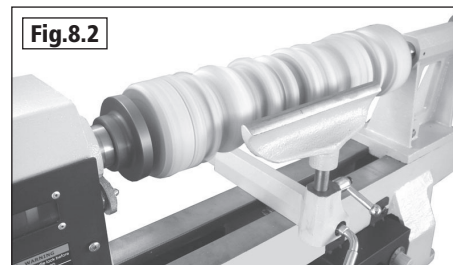

The lathe is set up for a typical faceplate turning operation. See Fig 8.3.

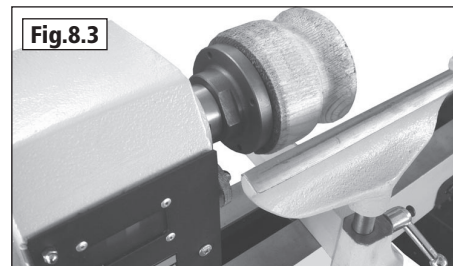

### In the Event of a Blockage or if the Machine Stalls

If the lathe stalls due to a dig in, simply removing the turning tool from the work piece will normally allow the work piece to start turning again.

The inverter drive unit of the lathe incorporates a thermal overload device. In case of a severe dig in, or if the work piece becomes trapped against a fixed part of the lathe, the thermal overload will usually cut power to the motor. If the thermal overload does not activate immediately switch the machine off by pressing the red button marked 'O' on the control box. Locate and rectify the source of the blockage and ensure that the work piece can be rotated freely by hand before attempting to re-start the machine.

Turn the speed control knob to its lowest setting before attempting to re-start the machine.

To re-start the machine, press the green button marked 'I' on the control box. Gradually increase the spindle speed by adjusting the speed control knob until the desired speed is reached.

### In the Event of a Power Failure

The lathe is fitted with a no volt release (NVR) switch to protect the user against automatic starting of the machine when power is restored after a power failure.

In the event of a power failure, first locate and rectify the source of the failure. If the fault is within the power circuit of the workshop, there may be an underlying cause (circuit overload etc.) that should be investigated by a qualified electrician, before attempting to restore the power source.

Turn the speed control knob to its lowest setting before attempting to re-start the machine.

Once the power is restored, the machine can be re-started by pressing the green button marked 'I' on the switch.

# 9. Intended Use of the Lathe & Basic Woodturning Instructions

## Intended Use of the Lathe

This lathe is designed for turning wood between centres or on the headstock (using appropriate accessories), for sanding and applying finishes to wood. It is not to be used for any other purpose. Doing so will invalidate the warranty and may cause serious harm to the user.

## Health & Safety

Please read the health and safety instructions contained in this manual and the specific health and safety instructions relating to woodturning. In addition, it is recommended to ensure your work area is adequately equipped with dust extraction and air filtration equipment.



Respiratory equipment should also be used to greatly reduce lung exposure to harmful fine dust. Always establish the properties of the timber being turned and take extra care when working with harmful and carcinogenic materials.



Eye protection must always be worn. Due to the nature of woodturning, shavings, dust and splinters can be thrown at fast speeds, making adequate eye protection essential.

## Mounting Timber to a Faceplate or Chuck

Before mounting the workpiece to a faceplate or chuck (not supplied), it is advisable to shape the timber into as cylindrical a profile as possible, see **fig 9.1**. Turning unbalanced timber increases lathe vibration, the risk of it being thrown from the lathe, increased risk of chisel dig in and makes correct positioning of the tool rest difficult due to variable distances.

## Mounting Timber Between Centres

When turning between centres, it is essential to correctly and securely mount the timber so as to reduce the risk of it being thrown from the lathe. It is also essential to mount the timber as centrally as possible. This will reduce the amount of roughing out needed and also maximise the possible diameter of the final piece.

1. Using a square or rectangular profile blank, draw two lines, one from each opposing diagonal corner to the other, at each end of the blank. The point where the lines intersect indicates the centre of the blank. See **fig 9.2**. If using irregular shaped timber, a centre finder is an invaluable tool.
2. Take the four prong centre supplied with the lathe and place its point directly on to the centre point of one end of the blank. Using a soft mallet (of either plastic, rubber or wood) tap the four prong centre with reasonable force until it bites into the timber. See **fig 9.3**.
3. Carefully place the four prong centre into the headstock spindle of the lathe, **fig 9.4**, and ensure that it is correctly seated in the spindle by tapping it firmly into place with a mallet.
4. Slide the tailstock up the bed until the tailstock centre is almost touching the other end of the blank. Lock the tailstock in position and use the hand wheel to extend the tailstock centre until it grips the blank firmly at the centre point. See **fig 9.5**. Then use the tailstock locking handle to secure the position. The blank is now successfully mounted and ready to be turned.

## Positioning the Tool Rest

It is extremely important to ensure the tool rest is correctly positioned before turning on the lathe. Place the tool rest close to the timber, allowing enough room to manoeuvre the chisel with ease. Spin the timber by hand to ensure it does not come into contact with the tool rest. If the lathe is started without checking this and the timber hits the tool rest, there is a risk the timber could be thrown from the lathe and cause injury. Never attempt to reposition the tool rest while the lathe is in motion.

Tool rest height is also important and varies depending on the chisel

Fig.9.1

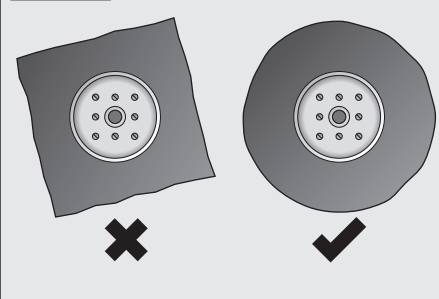

Fig.9.2

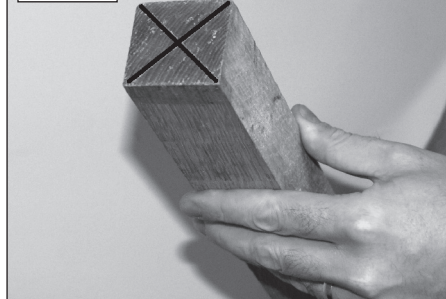

Fig.9.3

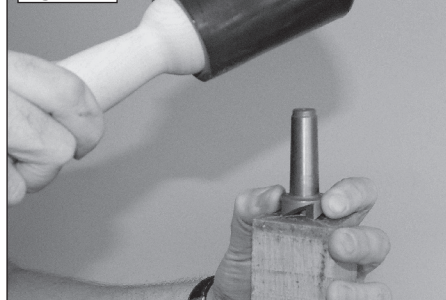

Fig.9.4

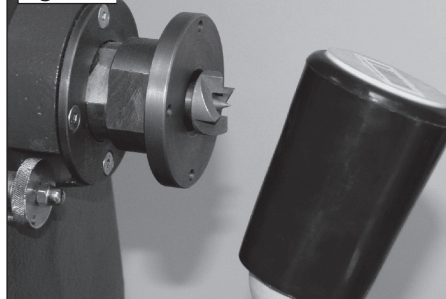
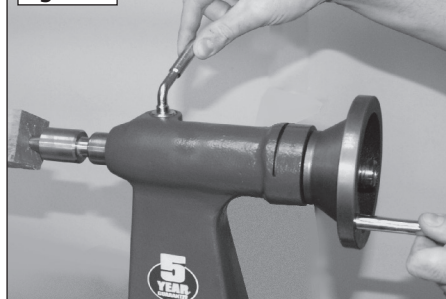

Fig.9.5



# 9. Intended Use of the Lathe & Basic Woodturning Instructions - cont.

being used. When using a roughing gouge, the cutting edge should come into contact with the centre of the workpiece, see **fig 9.6**. If using a skew chisel, the cutting edge should be applied approximately 3/8" (10 mm) above the centre height, see **fig 9.7**. A spindle gouge's cutting edge should come into contact with the workpiece approximately 3/8" (10 mm) below its centre, see **fig 9.8**.

## Using the Roughing Gouge

The first step when turning between centres is invariably to 'rough out' the blank. This involves taking a square section blank and paring it down with a roughing gouge to a cylindrical profile, ready to shape into the final piece. Roughing gouges are usually sharpened to have the bevel at a 45° angle. Using the tool rest to support the blade, offer the blade to the workpiece at an angle, see **fig 9.9**. When offering the roughing gouge to the workpiece, the bevel should be rubbing it, without cutting. To make a cut, gently raise the handle of the tool in order to bring the cutting edge into contact with the timber. Using light passes, move the blade outwards towards the same edge of the timber which the blade is facing, **fig 9.9**. Never move the tool backwards, as this introduces the risk of splintering the wood and causing injury.

## Using the Spindle Gouge

A spindle gouge is used to shape the final profile of a spindle and is capable of finer work than a roughing gouge. It is designed specifically for cutting coves or valleys. The blade should come into contact with the wood at just below the centre line. Resting it on the tool rest, apply the blade to the workpiece at an angle, see **fig 9.10**, rubbing the bevel onto it. Raise the handle to apply the cutting edge and make cuts. As with the roughing gouge, use controlled and light passes, trying to not remove too much wood at once. Never attempt to use a spindle gouge for working on bowls or hollow form work as the angle of the cutting bevel of the gouge is too shallow and will cause it dig in to the work piece or snatch the tools from your hands.

## Using the Skew Chisel

Skew chisels are available in both flat and oval profiles. The curved profile is favoured by many as it gives better results more easily. Skew chisels are ideal for creating beads, refining the profiles and can be used to create a final smooth finish to the workpiece. The skew chisel should be applied to the workpiece horizontally with the blade resting on the tool rest, **fig 9.11**, again with the bevel rubbing the workpiece and raising the handle to take careful, controlled cuts.

## Further Operations

The guidelines above give basic instructions on some of the most common woodturning procedures. There are a wide variety of specialised chisels and many complementary accessories available for Record Power lathes which enable a huge variety of work to be created. For further instructions on more advanced safe and effective woodturning, please seek professional training.

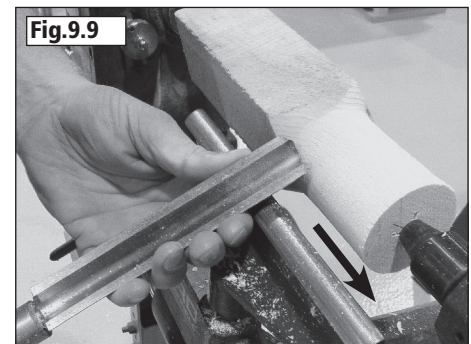
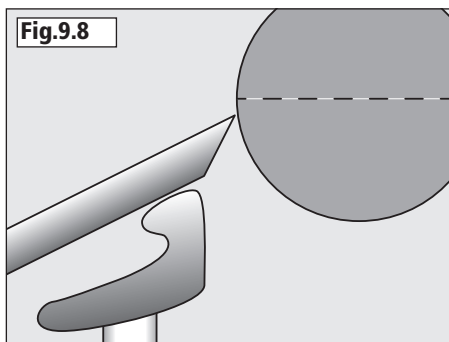
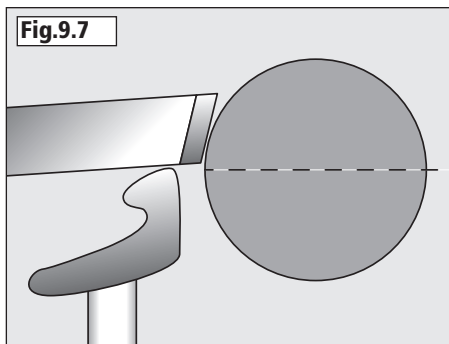
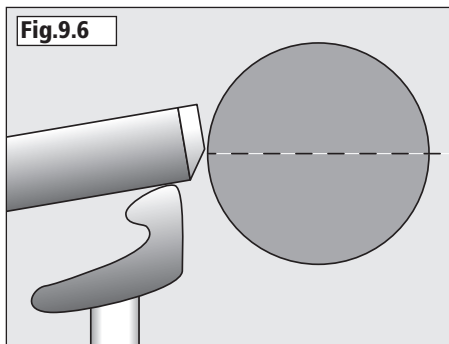

## Speeds of the Lathe

To ensure the safest possible use of the lathe, it is important to understand which speeds are suited to which tasks. In general, the slower speeds should be used for the initial turning and roughing out of large pieces and the slowest speed should be used when large pieces are out of balance. This will reduce the possibility of the workpiece being thrown from the lathe.

Medium speeds are ideally suited for general purpose work which doesn't place heavy loads on the spindle of the lathes, for example when creating the profiles of spindles and some smaller bowl turning.

The fastest speeds should be used only for small diameter work, where the size of workpiece is relatively small and therefore poses a lower risk of causing damage. Extra care should be taken when turning at the fastest speeds, using only a relatively light touch.

When sanding, care should be taken to not burn the operator's hands or the workpiece. It is recommended to not exceed the speed used for the last turning operation. If in doubt, use a slow speed.

# 10. Dust Extraction

## 10.1 The Importance of Dust Extraction

Before the machine is started, ensure that adequate dust extraction provisions have been installed. Dust extraction is extremely important not only for health and safety but also for the correct upkeep of the machine. Saw dust can cause the machine not to operate properly or even fail completely. By keeping the machine free of large amounts of waste the performance will be optimised.

If large amounts of MDF or toxic woods are to be cut we recommend that there is a good ventilation system in place and that a particle mask is worn as minimum protection.

In addition, it is recommended that air filters are used in all workshops to ensure collection of potentially harmful airborne particles which are not collected directly from the machine.

## 10.2 Record Power Extractors

Record Power offer a range of high quality dust extractors, starting at the single motor 45 litre RSDE1 right up to the 200 litre twin motor DX5000. We offer both drum and bag type extractors high filtration models filter down to 0.5 micron providing protection from harmful fine dusts such as MDF. Chip collectors filter down to 5 micron. All Record Power dust extractors & chip collectors have 100mm inlets and hoses.

### RSDE1 High Filtration Dust Extractor

Drum type extractor, 45 litre capacity, single 1 kW motor, suitable for intermittent use i.e must be switched off for 20 minutes every hour.

**0.5 micron filtration; suitable for MDF**

### RSDE2 High Filtration Dust Extractor

Drum type extractor, 50 litre capacity, single 1 kW motor, suitable for intermittent use i.e must be switched off for 20 minutes every hour.

**0.5 micron filtration; suitable for MDF**

### DX1000 High Filtration Dust Extractor

Drum type extractor, 45 litre capacity, single 1 kW motor, suitable for intermittent use i.e must be switched off for 20 minutes every hour.

**0.5 micron filtration; suitable for MDF**

### DX4000 High Filtration Dust Extractor

Drum type extractor, 80 litre capacity, twin 1 kW motor, suitable for heavy usage i.e if one motor is switched off for 20 minutes then the other can be used thus enabling continuous usage. Or both motors can be used simultaneously giving maximum suction but in this mode the extractor must be switched off for 20 minutes every hour.

**0.5 micron filtration; suitable for MDF**

### DX5000 High Filtration Dust Extractor

Bag type extractor, 200 litre capacity, twin 1 kW motor, suitable for heavy usage i.e if one motor is switched off for 20 minutes then the other can be used thus enabling continuous usage. Or both motors can be used simultaneously giving maximum suction but in this mode the extractor must be switched off for 20 minutes every hour.

**0.5 micron filtration; suitable for MDF**

### CX2600 Chip Collector

Large capacity chip collector, with a powerful 0.37 kW induction motor. An extremely smooth running unit suitable for continuous usage. Very quiet impeller system extracts dust and chippings.

**5 micron filtration; unsuitable for MDF**

### CX3000 Chip Collector

Larger capacity chip collector, with a more powerful 0.75 kW induction motor and heavy duty construction. An extremely smooth running unit suitable for continuous usage. Very quiet impeller system extracts dust and chippings.

**5 micron filtration; unsuitable for MDF**

### AC400 Two Stage Air Filter

Useful for reducing nuisance dust, particularly in smaller workshops. This unit provides effective two stage filtration for areas up to 113 M<sup>3</sup>.

**1 micron filtration**

### AC2 Three Stage Air Filter

This triple stage filter offers highly effective filtering of particles down to 1 micron. Ideal for use in medium to large workshops up to 212 M<sup>3</sup>.

**1 micron filtration**

	RSDE1	RSDE2	DX1000	DX4000	DX5000	CX2600	CX3000	AC400	AC2
<b>Bandsaws</b> <b>Circular saws</b> <b>Sanders</b> Intermittent usage	✓ Recommended	✓ Recommended	✓ Recommended	✓ Recommended	✓ Recommended				
<b>Bandsaws</b> <b>Circular saws</b> <b>Sanders</b> Heavy usage				✓ Recommended	✓ Recommended				
<b>Planer Thicknessers</b> <b>Spindle Moulders</b> <b>Universals</b> Intermittent usage				✓ Can be used	✓ Recommended	✓ Recommended	✓ Recommended		
<b>Planer Thicknessers</b> <b>Spindle Moulders</b> <b>Universals</b> Heavy usage				✓ Can be used	✓ Recommended	✓ Recommended	✓ Recommended		
<b>Dust Extraction System</b> Intermittent usage				✓ Can be used	✓ Recommended				
<b>General Workshop Air Filtration</b> Heavy usage								✓ Recommended	✓ Recommended

# 11. Electrical Connection & Wiring Diagram

Machines supplied for use in the UK are fitted with a 3 pin plug conforming to BS1363, fitted with a fuse conforming to BS1362 and appropriate to the current rating of the machine.

Machines supplied for use in other countries within the European Union are fitted with a 2 pin Schuko plug conforming to CEE 7/7.

Machines supplied for use in Australia & New Zealand are fitted with a 3 pin plug conforming to AS/NZS3112.

In all cases, if the original plug or connector has to be replaced for any reason, the wires within the mains power cable are colour coded as follows:

## 230 V (Single Phase)

Brown: Live (L)  
 Blue: Neutral (N)  
 Green and Yellow: Earth (E)

The wire coloured brown must always be connected to the terminal marked 'L' or coloured red.

The wire coloured blue must always be connected to the terminal marked 'N' or coloured black.

The wire coloured green and yellow must always be connected to the terminal marked 'E' or with the earth symbol:



or coloured green / green and yellow.

It is important that the machine is effectively earthed. Some machines will be clearly marked with the double insulated logo:



In this case there will not be an earth wire within the circuit.

In the case of the BS1363 plug for use in the UK, always ensure that it is fitted with a fuse conforming to BS1362 appropriate to the rating of the

machine. If replacing the original fuse, always fit a fuse of equivalent rating to the original. Never fit a fuse of a higher rating than the original. Never modify the fuse or fuse holder to accept fuses of a different type or size.

Where the current rating of the machine exceeds 13 A at 230 V, or if the machine is designated for use on a 400 V 3 phase supply a connector conforming to BS4343 (CEE17 / IEC60309) will be used.

230 V machines will be fitted with a blue 3 pin connector. The wiring for this type of this connector will be the same as shown above.

400 V, 3 phase machines will be fitted with a red 4 or 5 pin connector. The wiring for this type of connector is as shown below:

## 400 V (3 phase)

Brown: Live (L1)  
 Black: Live (L2)  
 Grey: Live (L3)  
 Blue: Neutral (N)  
 Green and Yellow: Earth (E)

The wire coloured brown must always be connected to the terminal marked 'L1'.

The wire coloured black must always be fitted to the terminal marked 'L2'.

The wire coloured grey must always be connected to the terminal marked 'L3'.

The wire coloured blue must always be connected to the terminal marked 'N' or coloured black.

The wire coloured green and yellow must always be connected to the terminal marked 'E' or with the earth symbol

If in doubt about the connection of the electrical supply, always consult a qualified electrician.

*the frequency convertor*

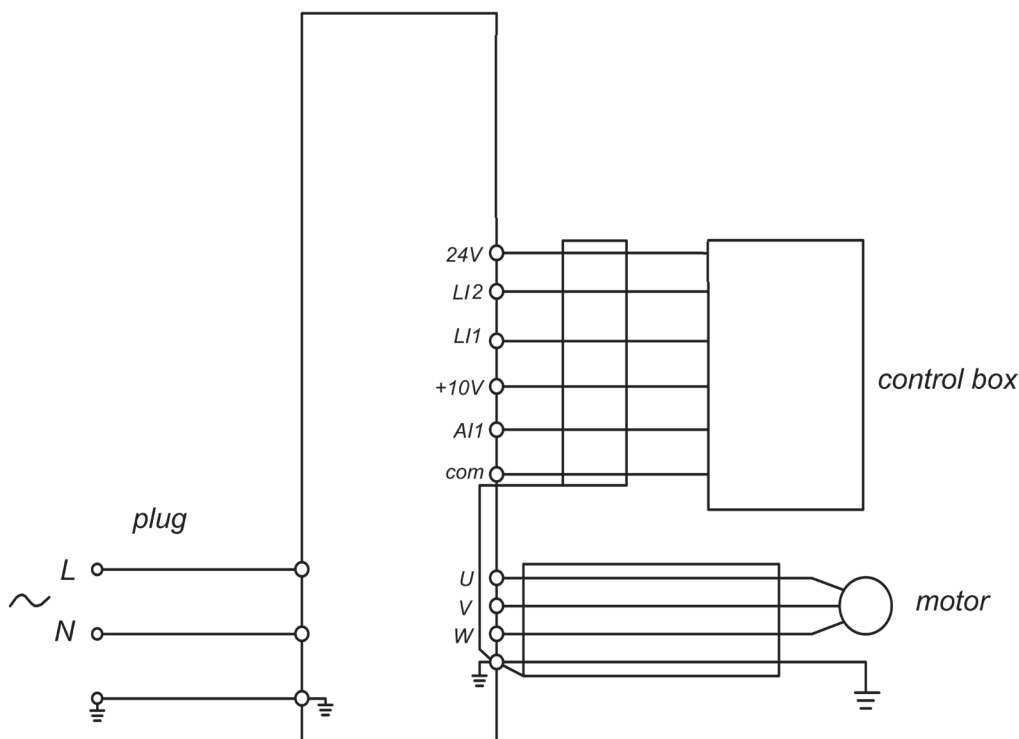

# 12. Parts List & Diagram

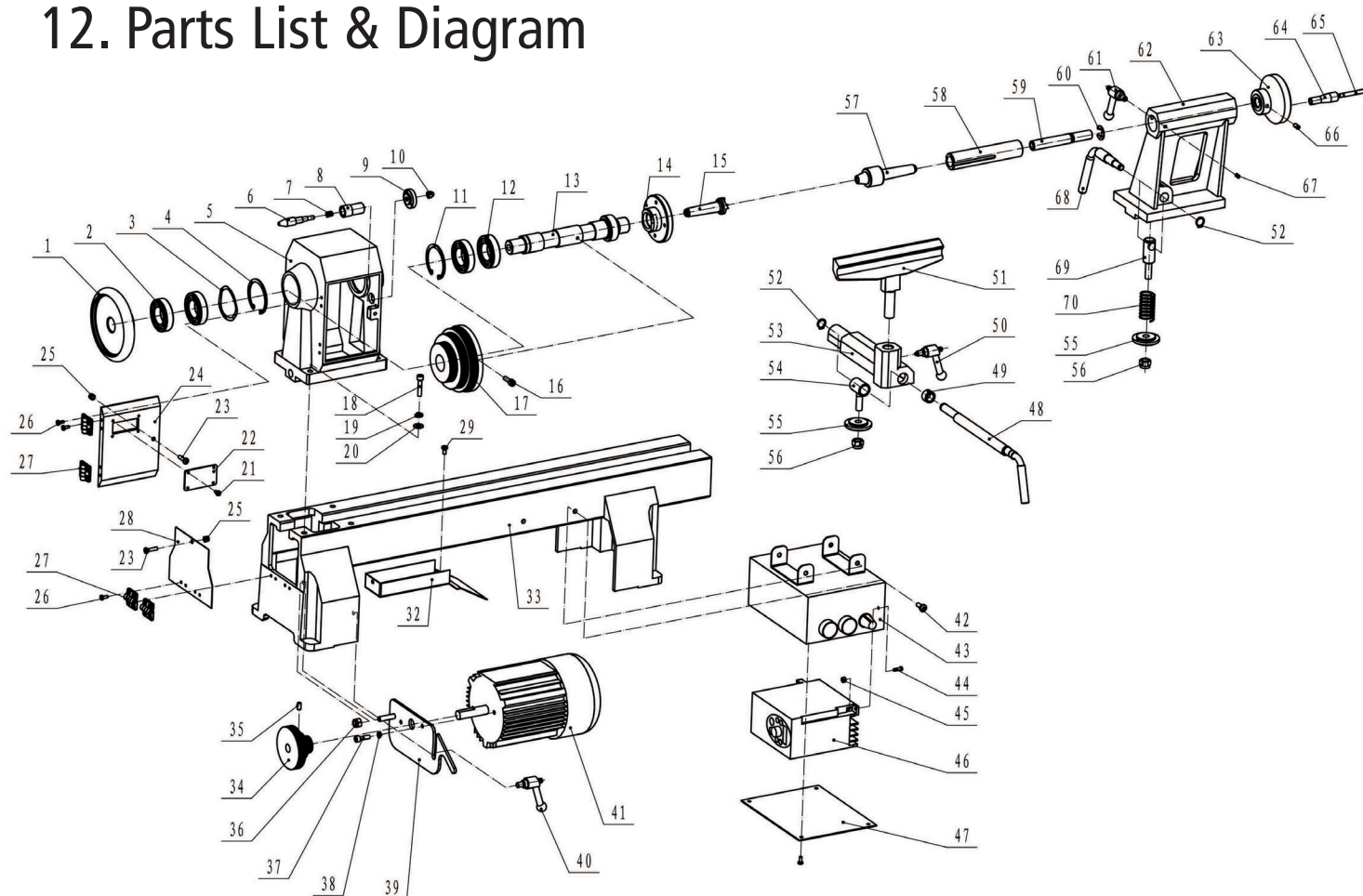

## Ref No. Description

- 1 Handwheel
- 2 Bearing
- 3 Wave washer
- 4 Retaining ring
- 5 Spindle head
- 6 Indexing lock pin
- 7 Spring
- 8 Indexing lock tube
- 9 Indexing lock nut
- 10 Cap nut M6
- 11 Retaining ring
- 12 Bearing
- 13 Spindle
- 14 Faceplate
- 15 Spur centre
- 16 Screw M6X16
- 17 Spindle pulley
- 18 Hex. Socket set screw
- 19 Spring washer 6
- 20 Flat washer 6
- 21 Rivet 3x7
- 22 Plastic window
- 23 Pan head screw M6X16
- 24 Spindle head cover
- 25 Locknut M6
- 26 Pan head screw M4X8
- 27 Hinge
- 28 Bed plate
- 29 Pan head screw
- 30 Lifting handle clamping
- 31 Lifting handle
- 32 Cover plate
- 33 Bed
- 34 Motor pulley
- 35 Hex. Socket set screw

## Ref No. Description

- 36 Locknut M8
- 37 Hex. Socket head screw
- 38 Spring washer 6
- 39 Belt tension handle
- 40 Locking arm
- 41 Motor
- 42 Pan head screw
- 43 Switch box
- 44 Pan head screw
- 45 Hex nut M4
- 46 Transducer
- 47 Plate
- 48 Locking lever
- 49 Collar
- 50 Locking arm
- 51 Tool rest
- 52 Retaining ring
- 53 Tool rest base
- 54 Clamp bolt cover
- 55 Position plate
- 56 Lock nut M10
- 57 Live centre
- 58 Axle sleeve
- 59 Bolt
- 60 Retaining ring
- 61 Locking arm
- 62 Tail stock
- 63 Handwheel
- 64 Handwheel handle
- 65 Screw
- 66 Hex socket set screw
- 67 Set screw M5X10
- 68 Lock lever
- 69 Thread shaft
- 70 Spring

# EU Declaration of Conformity

**Cert No: EU / DML305-VS / 1**

**RECORD POWER LIMITED,**

Unit B, Ireland Industrial Estate  
Adelphi Way, Staveley, Chesterfield, Derbyshire S43 3LS  
declares that the machinery described:-

1. Type: **Variable Speed Midi Lathe**
2. Model No: **DML305-VS**
3. Serial No .....

Conforms with the following directives:-

MACHINERY DIRECTIVE (repealing / replacing Directives)	2006/42EC
LOW VOLTAGE DIRECTIVE	2006/95EC
ELECTROMAGNETIC COMPATIBILITY DIRECTIVE	2004/108EC EN 55014-1:2006 EN 55014-2:1997/+A1:2001/+A2:2008 EN 61000-3-2:2006 EN 61000-3-3:2008

and conforms to the machinery example for which the  
EC Type-Examination Certificate No. **SH09081132-001, SH09081132-002, SH09081133-001**  
at: Intertek Testing Services Shanghai, Building No 86, 1198 Qinzhou Rd (North), Shanghai 200233

and complies with the relevant essential health and safety requirements.



Signed.....Dated: **01/02/2010**

**Andrew Greensted**  
Managing Director



**RECORD POWER**  
ESTABLISHED 1909®

Woodworking Machinery & Accessories

**United Kingdom**

**Record Power Ltd**

Unit B Adelphi Way, Ireland  
Industrial Estate, Staveley,  
Chesterfield, Derbyshire S43 3LS

Tel: 01246 561 520  
www.recordpower.co.uk

**Eire**

**Record Power Ltd**

Unit B Adelphi Way, Ireland  
Industrial Estate, Staveley,  
Chesterfield, Derbyshire S43 3LS

Tel: 01246 561 520  
www.recordpower.co.uk

**Australia**

**Tools 4 Industry**

Po Box 3844  
Parramatta 2124

Tel: 1300 124 422  
Fax: 1800 262 725  
www.recordpower.com.au

**New Zealand**

**Tools 4 Industry**

Po Box 276079  
Manukau City 2241

Tel: 0800 142 326  
Fax: 09 2717 237  
www.recordpower.co.nz

Made in China